

aftermarket replacement for:
FAE
type-c 1 screw part# - 111530012-K

XFM-FA113
DUAL WOOD CARBIDES

CUTTER TYPE	STEEL TYPE	STEEL HARDNESS	SINGLE BOLT REQUIRED	WEIGHT	A	B	C
Wood	42CrMo	HRC40-42	(1) M20x1.5x60 SKT	3.39 lbs	2-3/8"	2-7/8"	1-7/8"

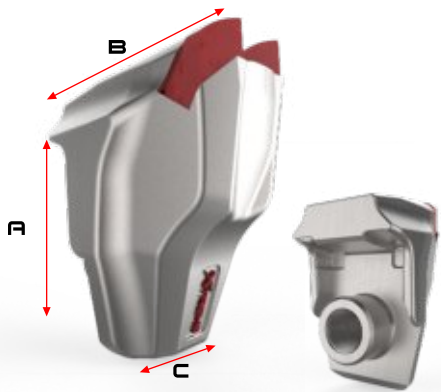

aftermarket replacement for:
FAE
type-c 1 screw part# - 111530012-K

XFM-FA114
DUAL WOOD CARBIDE W/SIDE PROTECTION

CUTTER TYPE	STEEL TYPE	STEEL HARDNESS	SINGLE BOLT REQUIRED	WEIGHT	A	B	C
Wood	42CrMo	HRC40-42	(1) M20x1.5x60 SKT	3.36 lbs	2-3/8"	2-7/8"	1-7/8"

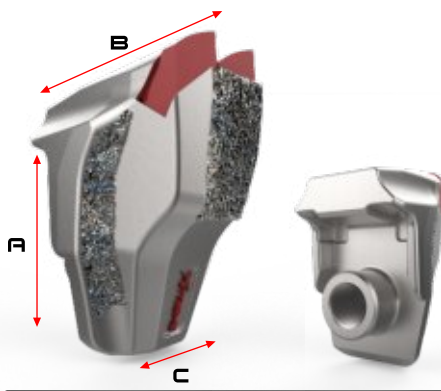

aftermarket replacement for:
FAE
type-c 1 screw part# - 111530012-K

XFM-FA221-HF
DUAL WOOD CARBIDE W/HARDFACING W/SIDE PROTECTION

CUTTER TYPE	STEEL TYPE	STEEL HARDNESS	SINGLE BOLT REQUIRED	WEIGHT	A	B	C
Wood	42CrMo	HRC40-42	(1) M20x1.5x60 SKT	3.63 lbs	2-3/8"	2-7/8"	1-7/8"

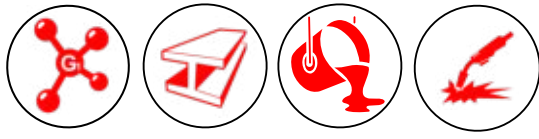
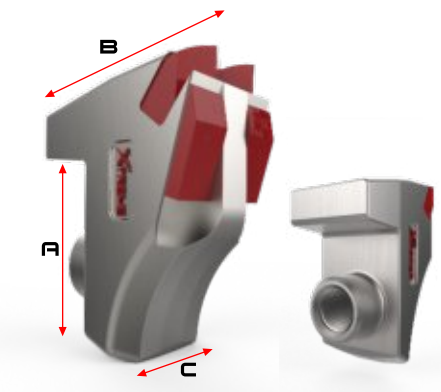

aftermarket replacement for:
FAE
type-c 1 screw part# - 1115300132-K

XFM-FA115
DUAL WOOD CARBIDE W/CARBIDE FACE PROTECTION

CUTTER TYPE	STEEL TYPE	STEEL HARDNESS	SINGLE BOLT REQUIRED	WEIGHT	A	B	C
Wood	42CrMo	HRC40-42	(1) M20x1.5x60 SKT	3.41 lbs	2-3/8"	2-7/8"	1-7/8"

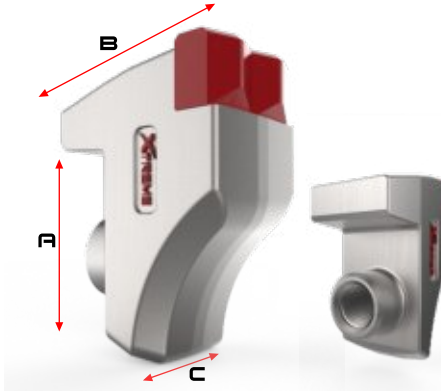

aftermarket replacement for:
FAE
type-c 1 screw part# - 112800009-K

XFM-FA116
ROCK CRUSHER CARBIDE

CUTTER TYPE	STEEL TYPE	STEEL HARDNESS	SINGLE BOLT REQUIRED	WEIGHT	A	B	C
Rock	42CrMo	HRC40-42	(1) M20x1.5x60 SKT	3.42 lbs	2-3/8"	2-7/8"	1-7/8"

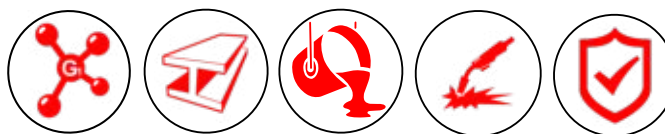
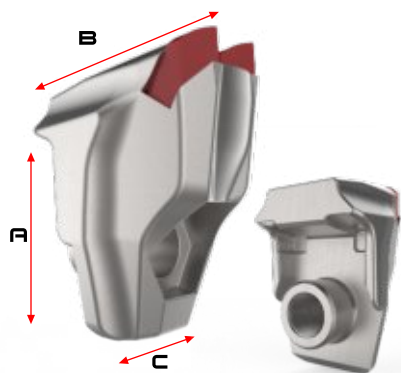

XFM-FA174

DUAL WOOD CARBIDE W/THRU-BOLT & NUT W/SIDE PROTECTION

CUTTER TYPE	STEEL TYPE	STEEL HARDNESS	SINGLE BOLT REQUIRED	WEIGHT
Wood	42CrMo	HRC40-42	(1) M20x1.5x80 SKT (1) M20x1.5 NUT	3.31 lbs

aftermarket replacement for:
FAE
type-c 1 screw part# - 111530012-K

A	B	C
LENGTH	WIDTH	WIDTH
2-3/8"	2-7/8"	1-7/8"

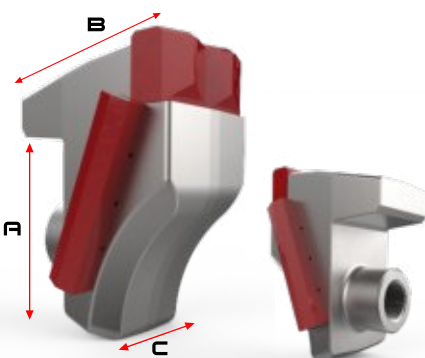

XFM-FA157-SL

LEFT SIDE SCRAPER

CUTTER TYPE	STEEL TYPE	STEEL HARDNESS	SINGLE BOLT REQUIRED	WEIGHT
Rock	42CrMo	HRC40-42	M20x1.5x60	3.55 lbs

aftermarket replacement for:
FAE
type-c 1 screw part# - 112700003-K

A	B	C
LENGTH	WIDTH	WIDTH
2-3/8"	2-7/8"	1-7/8"

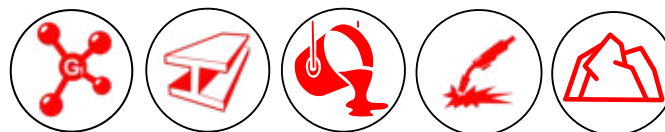
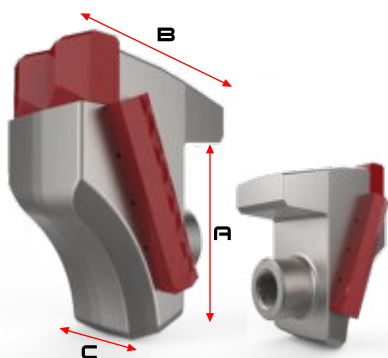

XFM-FA214-SR

RIGHT SIDE SCRAPER

CUTTER TYPE	STEEL TYPE	STEEL HARDNESS	SINGLE BOLT REQUIRED	WEIGHT
Rock	42CrMo	HRC40-42	M20x1.5x60	3.55 lbs

aftermarket replacement for:
FAE
type-c 1 screw part# - 112700002-K

A	B	C
LENGTH	WIDTH	WIDTH
2-3/8"	2-7/8"	1-7/8"

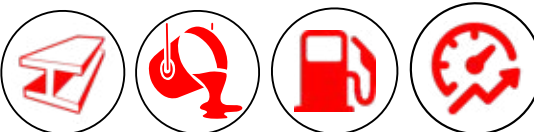
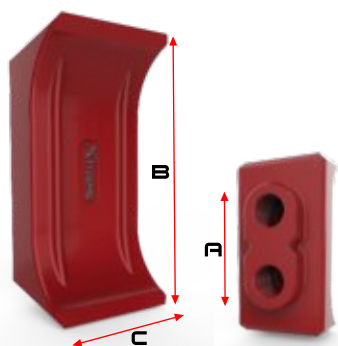

XFM-FA117-PL

REVERSIBLE PLANER KNIFE

CUTTER TYPE	STEEL TYPE	STEEL HARDNESS	SINGLE BOLT REQUIRED	WEIGHT
Wood G1	65Mn	HRC58-62	(1) 3/4-16 x 3" SKT	2.17 lbs

aftermarket replacement for:
FAE

A	B	C
LENGTH	WIDTH	WIDTH
2-1/2"	4-1/8"	2"

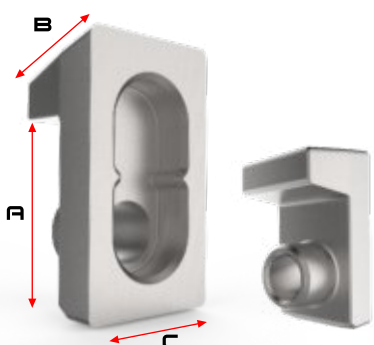

XFM-FA213-A

PLANER KNIFE HOLDER FOR XFM-FA117-PL

HOLDER FOR	STEEL TYPE	STEEL HARDNESS	SINGLE BOLT REQUIRED	WEIGHT
XFM-FA117-PL	42CrMo	HRC40-42	(1) 3/4-16 x 3" SKT	1.34 lbs

aftermarket replacement for:
FAE

A	B	C
LENGTH	WIDTH	WIDTH
2-1/2"	1-5/8"	1-7/8"

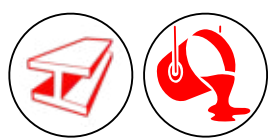
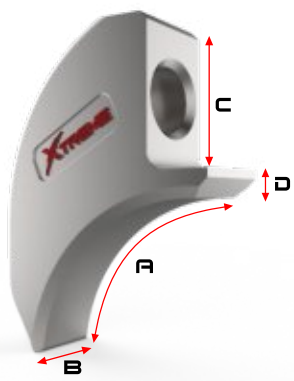

XFM-FA118-H
TOOTH HOLDER FIT 7-1/2" DIA DRUM

STEEL TYPE	STEEL HARDNESS	BOLT REQUIRED	WEIGHT
42CrMo	HRC40-42	(1) M20x1.5x60 SKT	6.71 lbs

1 SCREW HOLDER
used with - All FAE Type C - Screw Teeth

A	B	C	D
LENGTH	WIDTH	LENGTH	LENGTH
6"	1-3/4"	2-13/16"	1/2"

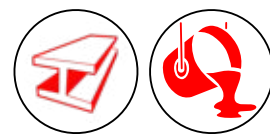
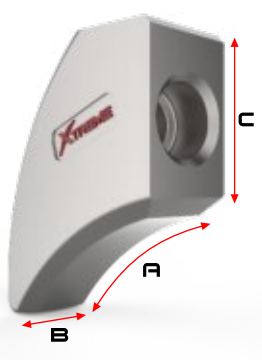

XFM-FA119-H
TOOTH HOLDER FIT 12" DIA DRUM

STEEL TYPE	STEEL HARDNESS	BOLT REQUIRED	WEIGHT
42CrMo	HRC40-42	(1) M20x1.5x60 SKT	5.40 lbs

1 SCREW HOLDER
used with - All FAE Type C - Screw Teeth

A	B	C
LENGTH	WIDTH	LENGTH
4-1/2"	1-3/4"	3"

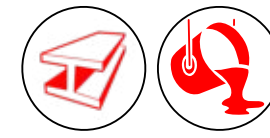
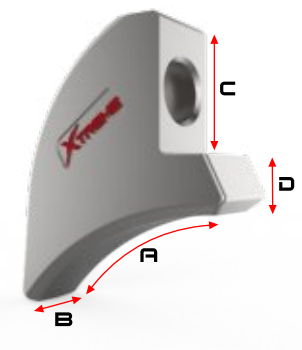

XFM-FA120-H
TOOTH HOLDER FIT 14" DIA DRUM

STEEL TYPE	STEEL HARDNESS	BOLT REQUIRED	WEIGHT
42CrMo	HRC40-42	(1) M20x1.5x60 SKT	7.96 lbs

1 SCREW HOLDER
used with - All FAE Type C - Screw Teeth

A	B	C	D
LENGTH	WIDTH	LENGTH	LENGTH
6"	1-3/4"	2-16/16"	1-1/8"

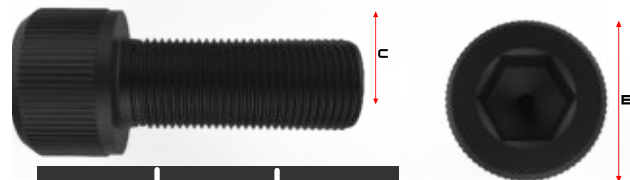

SOCKET BOLTS

PART NUMBER	THREAD SIZE	MATERIAL TYPE	GRADE	HEAD TYPE	DRIVE SIZE	A	B	C	FIT
						LENGTH	DIA	DIA	
M20x1.5x60 SKT	M20X1.5	Black Oxide Alloy Steel	12.9	Socket	17mm	60mm	30mm	30mm	All HM315B, HM415B Carbide Teeth
3/4-16x3" SKT	3/4-16"	Black Oxide Alloy Steel	8	Socket	5/8"	3"	1-1/8"	3/4"	XFM-FA117-PL

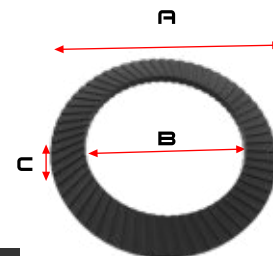

BEVELLED WASHER

PART NUMBER	MATERIAL TYPE	MATERIAL HARDNESS	SERRATED	A	B	C	FITS BOLTS
				OD	ID	THICKNESS	
M20W	Black Oxide Alloy Steel	C40	TOP & BOTTOM	29.85mm	20.85mm	1.86mm	M20 & 3/4"

IMPACT RACHET ADAPTER

PART NUMBER	MALE SOCKET SIZE	DRIVE SIZE	FITS BOLT SIZE
IMPACT-5/8	5/8"	3/4"	3/4-16" SKT
IMPACT-17	17mm	3/4"	M20x1.5 SKT

